

SPIRAL BEVEL GEARS

30 THROUGH 8 DIAMETRAL PITCH
STEEL—UNHARDENED AND HARDENED

20° PRESSURE ANGLE
35° SPIRAL ANGLE

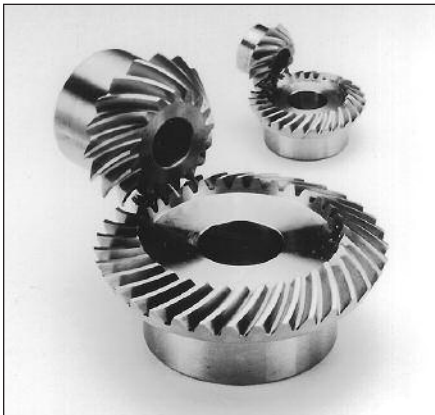

All Hardened steel gears have teeth only hardened and are equipped with standard keyways and setscrews, except as noted. All pinions are left hand.

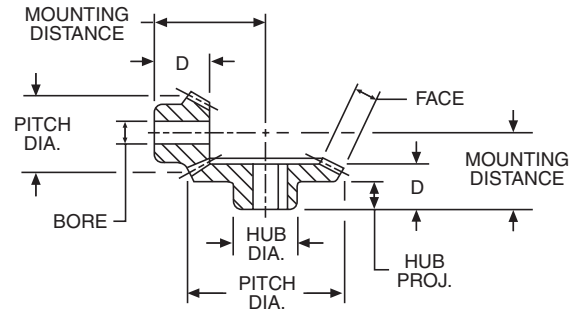

REFERENCE PAGES

Alterations — 149
 Horsepower Ratings — 71
 Lubrication — 149
 Materials — 150
 Selection Procedure — 67

STANDARD TOLERANCES

DIMENSION		TOLERANCE
BORE	All	±.0005

ALL DIMENSIONS IN INCHES
 ORDER BY CATALOG NUMBER OR ITEM CODE

Ratio	No. of Teeth	Pitch Dia.	Face	Bore	MD *	D	Hub		Catalog Number	Item Code	Catalog Number	Item Code	
							Dia.	Proj.					
30 DIAMETRAL PITCH													
										STEEL UNHARDENED		STEEL HARDENED	
2:1	26	.87	.14	.250	.688	.480	.75	.38	SS302-G	11938	—	—	
	13	.43		.1875	.750	.453	.38	.30	SS302-P	11940	—	—	
	26	.87	.14	.375	.688	.480	.75	.38	—	—	SH302-G	11914	
	13	.43		.1875	.750	.453	.38	.30	—	—	SH302-P†	11916	
19 DIAMETRAL PITCH													
2:1	26	1.37	.25	.500	1.000	.730	1.12	.42	SS192-G	11934	—	—	
	13	.68		.3125	1.062	.623	.62	.33	SS192-P	11936	—	—	
	26	1.37	.25	.625	1.000	.730	1.12	.42	—	—	SH192-G	11910	
	13	.68		.3125	1.062	.623	.62	.33	—	—	SH192-P†	11912	
14 DIAMETRAL PITCH													
2:1	26	1.86	.31	.625	1.188	.760	1.38	.50	SS142-G	11926	—	—	
	13	.93		.4375	1.250	.625	.81	.30	SS142-P	11928	—	—	
	26	1.86	.31	.750	1.188	.760	1.38	.50	—	—	SH142-G	11902	
	13	.93		.4375	1.250	.625	.81	.30	—	—	SH142-P	11904	
	32	2.29	.38	.750	1.375	.855	1.62	.56	SS142-1G	11930	—	—	
	16	1.14		.500	1.625	.848	1.00	.45	SS142-1P	11932	—	—	
	32	2.29	.38	.875	1.375	.855	1.62	.56	—	—	SH142-1G	11906	
	16	1.14		.500	1.625	.848	1.00	.45	—	—	SH142-1P	11908	
10 DIAMETRAL PITCH													
2:1	34	3.40	.57	1.000	1.875	1.135	2.00	.75	SS102-G	11922	—	—	
	17	1.70		.625	2.375	1.219	1.50	.63	SS102-P	11924	—	—	
	34	3.40	.57	1.1875	1.875	1.135	2.00	.75	—	—	SH102-G	11898	
	17	1.70		.625	2.375	1.219	1.50	.63	—	—	SH102-P	11900	
8 DIAMETRAL PITCH													
2:1	34	4.250	.71	1.250	2.500	1.575	2.88	1.06	SS82-G	11918	—	—	
	17	2.125		.750	3.125	1.677	1.88	.94	SS82-P	11920	—	—	
	34	4.250	.71	1.500	2.500	1.575	2.88	1.06	—	—	SH82-G	11894	
	17	2.125		.750	3.125	1.677	1.88	.94	—	—	SH82-P	11896	

*Mounting Distance (MD) must not be made less than dimension shown, see Page 144.

†No keyway or setscrew.